



The Auction Alliance Commercial & Platinum Expo

Cape Town, Johannesburg, **Durban**

An opportunity to market to a captive and focused audience.



Introduction to Auction Alliance

Auction Alliance is South Africa's largest Auction group in both value and volume of sales. With two decades of leading and stimulating the auction industry, we have sold many of the country's highest value and most high profile assets. In 2009 we took over R 7,5 Billion worth of property to the market with over 25,000 people attending our exhilarating and high profile auction events.

As a dynamic and entrepreneurial organization with an impressive historic track record of success, we regard ourselves as trusted advisors offering a total sales experience. As pioneers in Auctions, we have defined our own space and have constantly striven to find superior solutions for our clients through an uncompromising determination to achieve excellence in everything we undertake.

Over ten years ago we introduced Australian-type commercial multiple property Auctions to South Africa and have sold tens of Billions of Rand of real estate through this mechanism which has changed the face of the property industry in South Africa.

Our clients cover all sectors including individual investors, companies, corporations, government, advisors, financiers and property speculators. Every month thousands of sellers and buyers flock to our Auction venues across South Africa.



Alliance Commercial & Platinum Auctions

Every month we take hundreds of Commercial and high value Residential properties to Auction. In doing so we attract a captive audience of some of the highest nett worth individuals, investors and buyers within South Africa, whose full attention we have, giving us the perfect opportunity and forum in which to communicate with them.

Our Auctions are growing in popularity, volume and value month after month. It has become apparent that Auctions are becoming the most exciting and preferred way of buying and selling both commercial and residential real estate. Our Auctions are held at upmarket venues that are easily accessible and that offer a comfortable environment for the event. We have sold many billions of rands worth of real estate through our multiple Auctions over the past few years, and continue doing so.

We are constantly looking at new ways of adding value to our auction experience and are constantly working on improving the event and making it as beneficial and helpful as possible.

We believe that the auction event does not only have to be about buying the property itself, and the fact remains that property buyers are always in the market for a variety of other goods and services.



The Alliance Expo

We are proud to launch our monthly Alliance Expo, the perfect opportunity for Exhibitors to directly interact with thousands of wealthy investors and buyers who have just sold or bought investment real estate. This will be done via an Exhibition Forum which will be held at the auction venue, before, during and after the event. The Alliance Expo will occur at major city hotels in conjunction with our monthly Commercial and Platinum (luxury homes above R 5 million) Multiple Auction events.

Our Auction sales attract the country's most concentrated group of wealthy South African real estate owners at any one time, creating the perfect platform for cross selling. Every month our Exhibitors will be able to inform the thousands of buyers (and sellers) who flock to these property events in the search of a wide range of investment property. The Expo's will entertain clients and create an interesting environment with regard to various products and services on offer in the property arena.

The first Expo will be held in Cape Town in April 2010 followed by Johannesburg in May 2010 and Durban in June 2010.

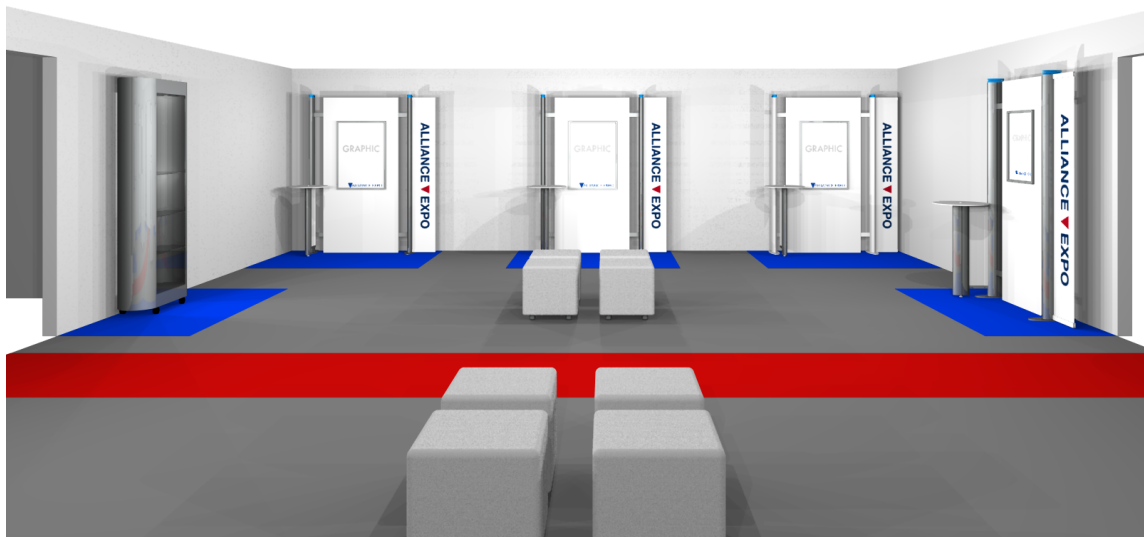

Impression of Alliance Expo Venue

Alliance Expo: Dates & Venues

Cape Town:	Crystal Towers Hotel & Spa, Century City.
Johannesburg:	Southern Sun Hotel, Grayston.
Durban:	Oyster Box Hotel, Umhlanga, 40N1, Gateway*.

Dates & Times: Platinum Alliance Expo @ 10h00 / Commercial Alliance Expo @ 12h00

Cape Town:	22nd April 2010
	19th May 2010
	9th June 2010
	15th July 2010
	19th August 2010
	16th September 2010
	21st October 2010
	25th November 2010
	8th December 2010 (Commercial Only)

Johannesburg:	18th May 2010
	14th July 2010
	18th August 2010
	15th September 2010
	20th October 2010
	24th November 2010
	7th December 2010 (Commercial Only)

Durban:	8th June 2010*
	13th July 2010*
	17th August 2010
	14th September 2010
	19th October 2010
	23rd November 2010
	9th December 2010 (Commercial Only)

Alliance Platinum & Commercial Expo Exhibitor

We are cordially inviting you to become part of our exciting Alliance Expo experience. You will now be able to directly interact and directly target the country's largest volume of serious property buyers, sellers, investors and associated service providers. As a paying Exhibitor, there are two Categories (see below) which you can participate in for our value-added services:

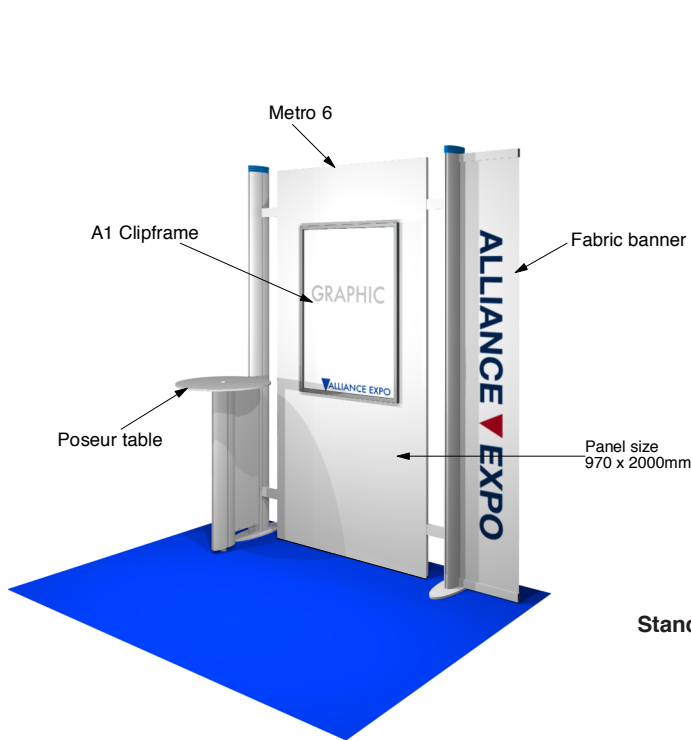

Stand Option 1

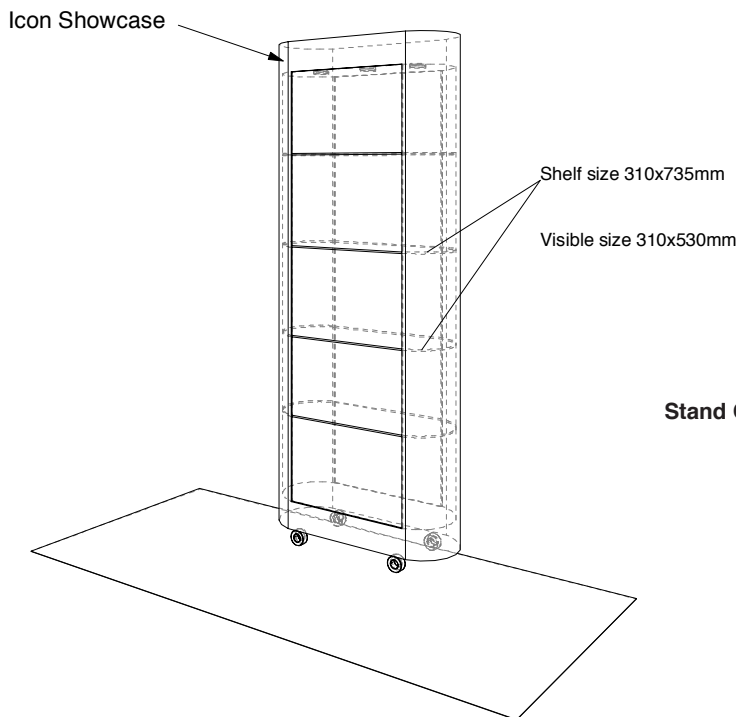
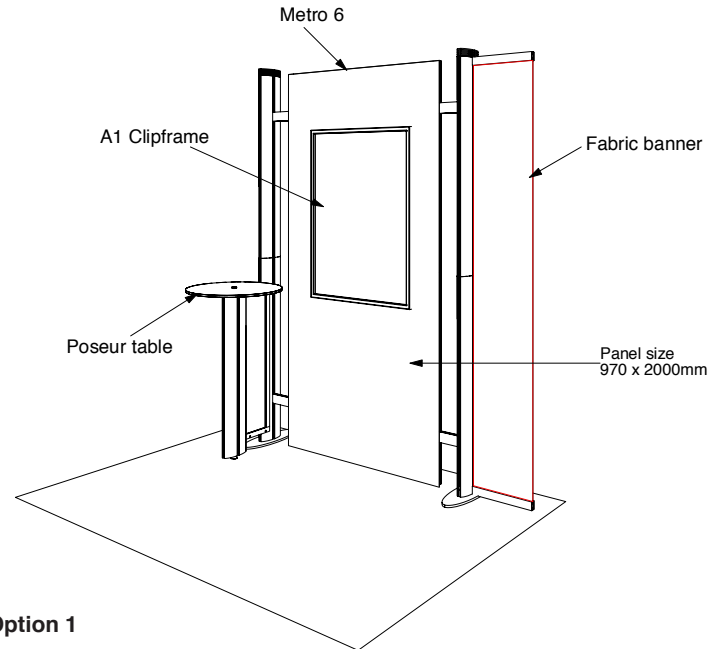

Stand Option 2

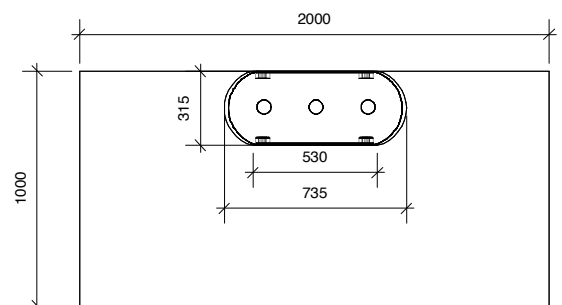
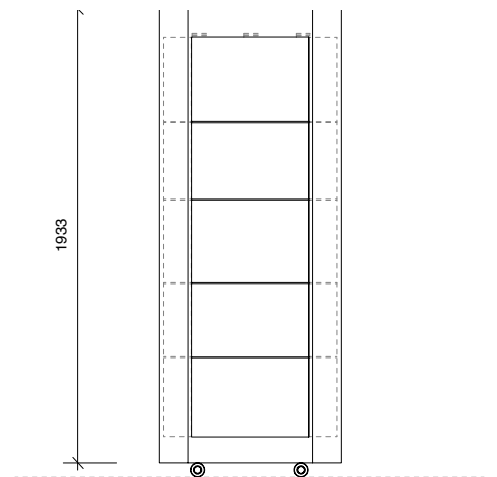

Examples of Alliance Expo Stands

Value-added Marketing Opportunities:

- a. Your Company logo will appear in the Auction Alliance Multi Magazine that displays all the properties to be Auctioned on the day.
- b. A click through from the Alliance Expo Link (front page of the Auction Alliance website) to a window that will display your logo and a brief overview of your Company, as well as a click through to your website. The Auction Alliance website receives over half a million unique impressions per month.
- c. A ticket to an Auction Alliance Investor Breakfast in 2010. (subject to availability)
- d. An email with your Company logo will be sent to specific Auction Alliance regional database; Gauteng – 28 000 emails.
- e. In our regional Alliance Weekly, in KwaZulu Natal: Sunday Tribune (102 250 print run), we will have a section on the back page called Alliance Expo, with the logo and/or a picture of all participating Exhibitors.

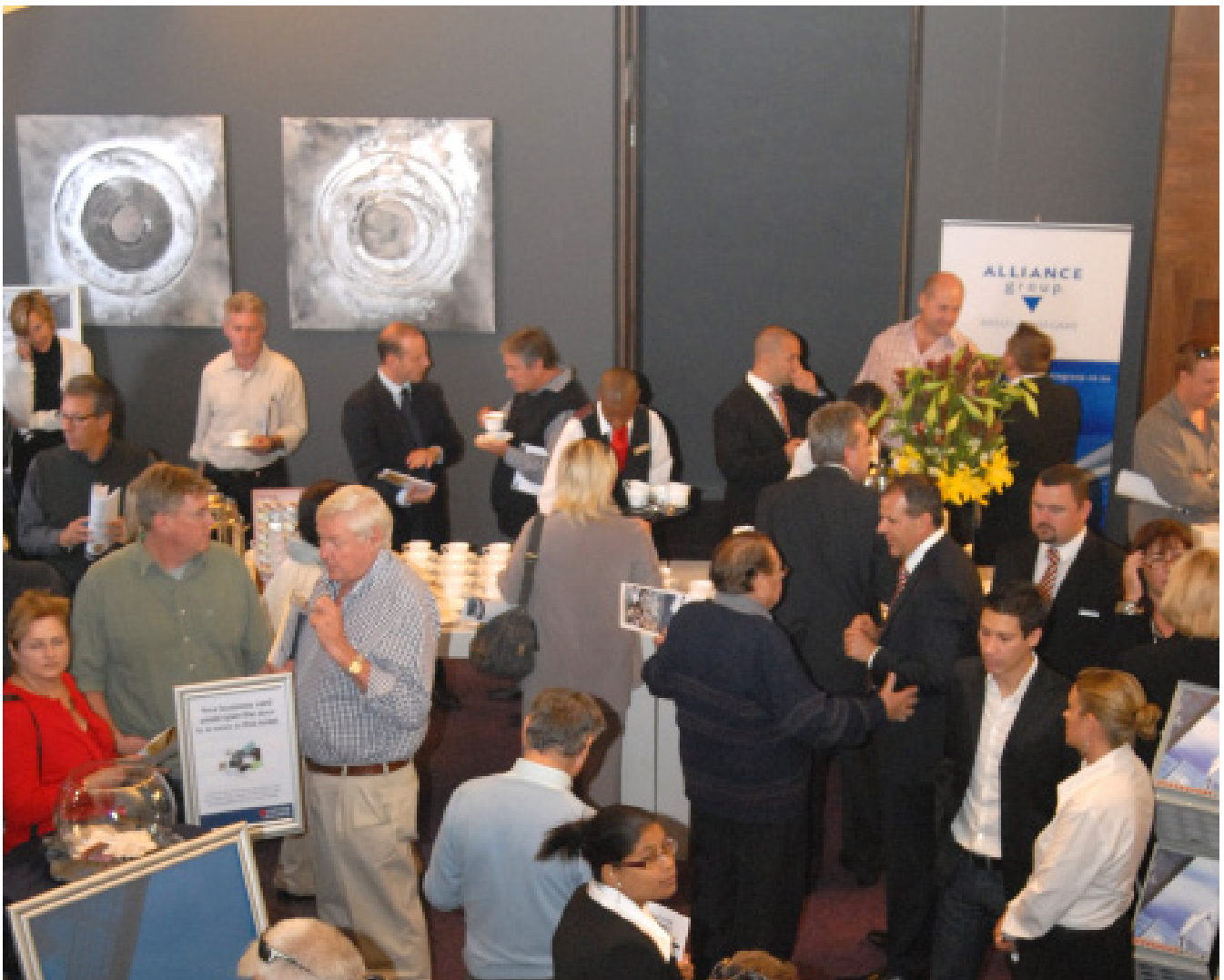

Cost to Exhibitor

If you would like your Company to exhibit your product(s) and/or service(s) at the Alliance Expo, including the added-value marketing services previously mentioned, there are two options on offer:

Stand Option 1:

- Size: 1 metre x 2 metres
- Description: 1 x Stand – including a rear wall with clip frame (A1) and a small table
16 mm raised floor with a carpet on top of it
- Cost: **R 3 500.00 including 14% VAT** – this includes all the appropriate value-added services.
Payment due immediately on signature of Booking Form.

Stand Option 2:

- Size: Various, depending on the showcase chosen
- Description: Icon Showcase – including 4 shelves, down lighting and a lock and key*
Please Note: The Exhibitor will be responsible for the key throughout the Expo and must ensure its return to the Exhibition Organiser after the event.
- Cost: **R 3 500.00 including 14% VAT** – this includes all the appropriate value-added services.
Payment due immediately on signature of Booking Form.

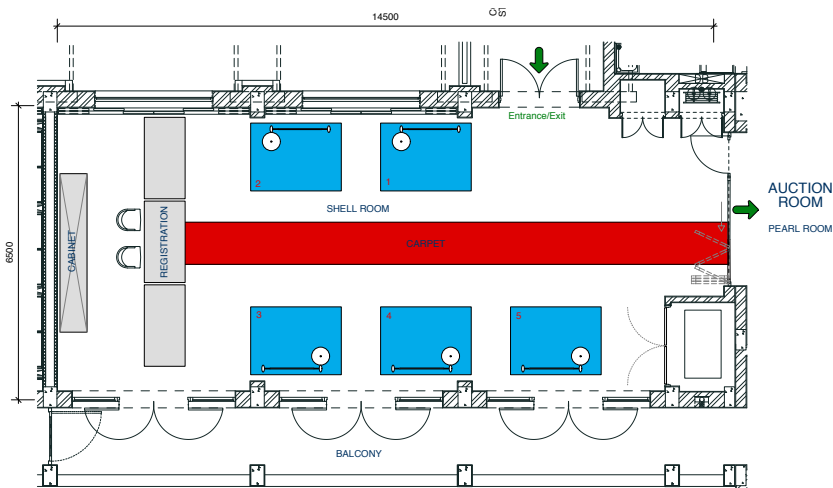

Proposed Alliance Expo Floor Plan Oyster Box Hotel

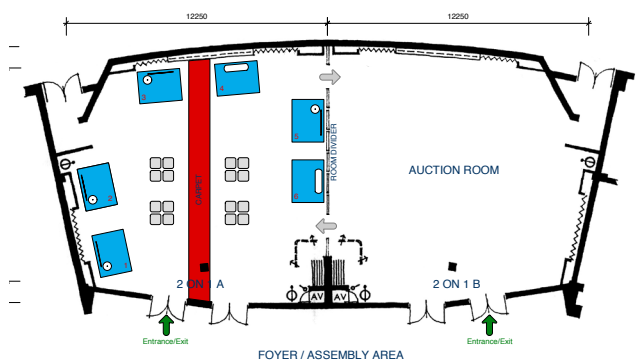

Proposed Alliance Expo Floor Plan 1ON1 Gateway

Alliance Expo: Rules and Regulations

- 1. Organiser & Management** - The Alliance Expo is organised and managed by the Organiser and its Management (RLM Communications) on behalf of the Alliance Group (Pty) Ltd.
- 2. Licence** - After the payment of the full contract price the Exhibitor will have a conditional and revocable licence to participate in the Alliance Expo. The Organiser will allocate the exhibit space ("Stand/s") which the Exhibitor is to occupy.
- 3. Allocation** - Stand/s will be allocated, by a Number at the Organiser's full discretion. The Organiser may be required to change the floor plan if necessary. The Organiser's determination with respect to allocation of the Stand/s will be binding on the Exhibitor. Where practicable Stand/s will be allocated according to the Exhibitor's sequence of choices
- 4. Size of Stand** - As per the diagram provided to the Exhibitor.
- 5. The Alliance Expo Stand** - The Alliance Expo Stand/s will be supplied by the Organiser. If a Stand/s is not required, there will be no reduction in the Cost stated on the Booking Form. It is important to inform the Organiser immediately if a Stand/s is not required. The Organiser will then allocate a specific area for the Exhibitor to exhibit in.
- 6. Exhibitor** - Exhibits will be limited to materials, products, or services of specific interest to registrants of the Alliance Expo. The Organiser reserves the right to determine the eligibility of any material, product or service for display or advertisement. Only one Principal can be represented by the Exhibitor in a single Stand. The decision of the Organiser with regard to whether any use or proposed use of the Stand/s is permitted under this Agreement shall be final.
- 7. Exhibitor Representatives' Responsibility** - Each Exhibitor must name at least one person to be his representative in connection with installation, operation, and removal of Exhibit. No one under the age of 16 shall be admitted during installation and dismantle.
- 8. Warranty** - The Exhibitor represents warrants and undertakes that it is entering into this Agreement as a Principal and not as agent or nominee of any third party, and the exhibits do not infringe or are likely to infringe any patent, trademark, copyright and other intellectual property right of any party and it agrees that in the event of any breach of the representations, warranties and undertakings herein contained this Agreement and the licence herein granted may be terminated by the Organiser (without the Organiser being liable for any damages or claim whatsoever and without prejudice to the Organiser's other rights and remedies) and the Exhibitor shall indemnify the Organiser and the Organiser against any and all costs, claims, demands, losses, liabilities, charges, actions and expenses.
- 9. Admission** - The Alliance Expo will be open to the general public. No registration fee will be charged by the Organiser. The Organiser reserves the right to refuse or regulate admission to any person.
- 10. Stand fitting Services** - The Exhibitor shall bear the cost of all stand fitting works. Stand fitting works can only be carried out by the Official Stand fitting Contractors appointed by the Organiser. Stand fitting works can however be carried out by an independent contractor appointed by the Exhibitor provided that such contractor shall have been approved by the Organiser. The Exhibitor shall bear the cost of all such stand fitting works, whether relating to the Shell Scheme or otherwise.
- 11. Electrical Works & Electricity Supply** - Only electricity can be used as a source of light or power at the Alliance Expo venue. Where the Exhibitor requires any electrical work in connection with its Exhibit, such work shall only be carried out by the Official Electrical Contractor appointed by the Organiser. The Exhibitor shall bear the cost of all such electrical work. A design plan or proposals for electrical installation must be submitted to reach the Organiser for review no later than 14 days prior the commencement of the Alliance Expo.
- 12. Photography** - All photographic rights are reserved to the Organiser. Any Exhibitor without the Organiser's permission has no right to take pictures or videos outside his stand/s.
- 13. Advertising Material & Publicity** - The Organiser may prohibit the distribution of any advertising material for any reason whatsoever during the Alliance Expo. The Organiser shall arrange and be responsible for all publicity related to the Alliance Expo, and no Exhibitor, or its agents, shall give or cause to be given any interview, public announcement, press statement, or any other publicity whatsoever intended to publicize the Alliance Expo as a whole, unless permission has been given by the Organiser.
- 14. Sound Devices & Noise Level** - Music, whether mechanical, vocal or instrumental, is prohibited. Any demonstrations or presentations must be a low volume so that nearby Exhibitors are not disturbed. Exhibitors must be mindful and ensure minimal noise during the Alliance Auction.
- 15. Set Up & Breakdown Time** - The set up starting time will be at 7.00 am on the morning of the Alliance Expo. All Exhibitors must be ready to exhibit by 9.00 am. The arrangement and payment for transporting goods to and from the Alliance Expo and the receiving of the goods are entirely the responsibility of the Exhibitor. Space not occupied by the close of the exhibit installation period will be forfeited by the Organiser and this space may be resold or re-assigned at the Organiser's discretion. The Exhibitor shall be solely responsible for the precautionary measures (such as guards or other means of protection) to protect the public from any moving or working exhibits. No exhibit shall be packed, removed or dismantled prior to the closing of the Alliance Expo. Breakdown can only take place one hour after the last Alliance Auction is complete. If the Exhibitor acts in breach of this provision, it is subject to pay as compensation for the distraction to the Alliance Expo's appearance, an amount equal to one-third of the total space charged for the Exhibitor's allocated area, in addition to all sums otherwise due under this Agreement. Additionally, breach of this provision could result in the loss of the Exhibitor's same Stand/s in future Alliance Expos produced by the Organiser.
- 16. Exhibitor Parking** - Each Exhibitor will be allowed 1 free parking exit ticket which will be given out during the Alliance Expo.
- 17. Food & Drink** - No food & drink will be handed out in the Alliance Expo area. Exhibitors are not allowed to eat & drink in the Alliance Expo area.
- 18. Direct Selling** - No money will exchange hands during the Alliance Expo. The Exhibitor will however be able to exchange details with a prospective client in order to facilitate a sale.
- 19. Cancellation** - Except as otherwise expressly provided herein, no refund will be made of any money paid to the Organiser under any circumstances whatsoever including in the event of the Exhibitor deciding not to participate in the Alliance Expo, The Organiser may retain all amounts then paid by the Exhibitor and also to recover all amounts due under this Agreement.
- 20. Liability & Risks** - The Exhibitor shall be liable for and shall insure, indemnify fully and effectively and hold the Organiser and its Management, the lessors of the premises where the Alliance Expo is held and all government, statutory and regulatory bodies and agencies of the country where the Alliance Expo is held and their respective directors, officers, agent and servants harmless against any and all costs, claims, demands, losses, liabilities, charges, actions and expenses which any of them may be subject to or may incur or which

may be made, claimed or instituted against them or any of them as a result of any act, breach of any of the terms of this Agreement, omission, conduct or failure of the Exhibitor or its directors, officers, agents, servants, invitees or independent contractors. The Exhibitor's aforesaid indemnity shall extend to all losses or injuries caused to any persons or property howsoever caused by the Exhibitor or its Exhibits or personnel, or otherwise arising while the said persons are upon or examining, observing or passing the Exhibit or Stand/s occupied by the Exhibitor, or by the demonstration of or otherwise in connection with the Exhibit. The liability or risks of loss or damage to the Exhibitor's employees or agents, or the Exhibits, shall be the responsibility of the Exhibitor. Exhibits shall be placed at the Exhibitor's own risks and the Organiser and its Management, their respective directors, officers and agents shall not be held responsible for any theft, damage, loss or destruction of the Exhibits. Under no circumstances will the Organiser and its Management, any government, statutory or regulatory body or agency or their respective directors, officers and agents make good or accept responsibility or be liable howsoever in respect of any damage, theft, loss or destruction of the Exhibits or any property, goods or articles or things whatsoever placed, deposited, brought into or left upon the Alliance Expo premises by the Exhibitor.

21. Insurance Policy - The Exhibitor shall take out and maintain from approved insurance companies an insurance policy in connection with the Alliance Expo in such form and for such amount as may be required by the Organiser from time to time. The Exhibitor shall punctually pay all premiums payable on such insurance policy. If the Exhibitor fails to comply with the provisions herein, the Organiser can (having immediate effect) cancel this Agreement. The Exhibitor shall make good all damage suffered by the Organiser and shall repay to the Organiser all the expenses incurred by the Organiser necessary by a breach or non-observance of this Clause without prejudice to any other rights of the Organiser. The Exhibitor shall procure the insurance company or companies which issued the insurance policy to waive their rights of subrogation against such person as the Organiser and its Management, as the case may be, may require.

22. Safety, Fire, Health & Other Laws - All fire, safety, health and other laws, rules and regulations imposed by the Organiser or local authorities and agencies or the lessor of the Alliance Expo premises must be strictly observed by the Exhibitor. The Exhibitor shall ensure that security arrangements in relation to the exhibits and the stands are adequate, effective and strictly observed at all time.

23. Prohibited Exhibits - No live military equipment, including munitions, aircraft armament, small arms ammunition and explosives, weapon systems, tactical missiles, rockets, etc shall be brought onto the Alliance Expo premises. Other kinds of exhibits may be prohibited by the Organiser. The Exhibitor is solely responsible for ensuring that all governmental and other regulatory approval required for the Exhibits and its participation in the Alliance Expo shall have been obtained prior to the date of the Alliance Expo, and shall be continuing throughout the Alliance Expo.

24. Losses - The Organiser and its Management shall not be responsible for damage to the Exhibitor's property howsoever caused or lost shipments either coming in or going out, or for money costs. The Exhibitor is responsible in all cases for the full contract price payable under this Agreement.

25. Termination / Postponement;

a) If, at the sole discretion of the Organiser, the Alliance Expo premises shall become unfit for occupancy or if the holding of the Alliance Expo or the performance of the Organiser and its Management of any of the provisions of this Agreement is interfered with by virtue of any cause or the Alliance Expo may or could in any way be affected by a cause not within the control of the Organiser and its Management, this Agreement and/ or the Alliance Expo (or any part thereof), may forthwith be terminated or cancelled or postponed or otherwise rearranged by the Organiser at its sole option, without the Organiser and its Management being liable in damages or otherwise to the Exhibitor. No refund will be made upon any postponement or rearrangement as aforesaid.

b) This Agreement may be terminated by the Organiser forthwith if in the Organiser's opinion the Exhibitor does not or may be unable to perform or comply with any of its obligations.

26. Right to Reject or Eject - The Organiser may reject, eject or prohibit the Exhibit in whole or in part, or the Exhibitor or its representatives, with or without giving cause. If an exhibit or Exhibitor is ejected for violation of any provisions of this Agreement or for any other stated reason, no refund of any portion of the contract price shall be made.

27. Right of Possession - The Exhibitor hereby grants to the Organiser, the right for purposes of ensuring the due performance by the Exhibitor of its obligations under this Agreement to possession of all property of the Exhibitor, including the Exhibits, on the Exhibitor premises. Such right to possession shall be superior to that of any person. All such property shall be deemed to be pledged to the Organiser as security for the performance by the Exhibitor of its obligations under this Agreement and the Organiser may remove, sell or otherwise dispose of all of the same upon such terms and conditions as it deems fit. If such property is not removed from the Alliance Expo premises immediately following the Alliance Expo, then the Organiser shall be at liberty to remove, sell or otherwise dispose of such property, and the net proceeds applied by the Organiser for such purpose as it deems appropriate. The Exhibitor shall indemnify the Organiser against all costs and expenses incurred in connection with such removal, safe or disposal, and any claim by a third party to any such property so sold or disposed of.

28. Sub-licensing - This licence to participate in the Alliance Expo is personal to the Exhibitor, is nontransferable and no licensing or sub-licensing may be granted by the Exhibitor to any other party. The Exhibitor shall not assign or sublet the Stand or any part thereof. The Organiser and its Management may assign or transfer its right and/or obligations. The Exhibitor may not assign or transfer any of its rights or obligations under this Agreement.

29. Organiser as Agent - All rights, powers and discretion exercised by the Management or consent or agreement given or made by the Management shall be deemed to be carried out as agent on behalf of the Organiser. The Management shall have no responsibility or liability whatsoever to the Exhibitor or any other party.

30. Liability, Exclusion & Limitation;

a) The Organiser and its Management shall not be responsible for delays, claims, demands, damages, losses, increased costs, liabilities, changes, actions, expenses or other unfavourable conditions, direct or indirect, consequential or otherwise, howsoever arising by virtue of any cause not within the control of the Organiser and its Management.

b) For purposes of this Agreement, the phrase "cause not within the control of the Organiser and its Management" shall include fire, casualty, flood, illness, risk of infection, epidemic, earthquake, explosion or accident, blockade, embargo, inclement weather, governmental restraints, restraints or orders of civil defence or military authorities, act of public enemy, riot or civil disturbance or commotion, malicious damage, sabotage, vandalism, act of terrorism, or other similar activities, strike, lockout, boycott or other labour dispute or disturbance, inability to secure sufficient labour, technical or other personnel, absence of premises required for the Alliance Expo, failure, impairment or lack of adequate transportation facilities, inability to obtain or condemnation, requisition or commandeering of necessary supplies or equipment, local, state or other law, ordinance, rule, order, decree or regulation, whether legislative, executive or judicial, and whether constitutional or unconstitutional, or Act of God and the words "act of" shall include "threat of or perceived threat of".

c) The aggregate liability of the Organiser (if any) shall under no circumstances (whether arising from breach of contract, tort or otherwise) exceed the amount of the total contract price paid by the Exhibitor for the licence herein granted. The person or persons appointed by the Organiser to undertake any official tasks including to the Official Stand fitting Contractor and the Official Electrical Contractor are independent contractors and are not agents of the Organiser and its Management.

31. **Governing Law & Jurisdiction** - This Agreement shall be governed by, and construed in accordance with the laws of the country of incorporation of the Organiser. The Exhibitor hereby irrevocably and unconditionally submits to the non-exclusive jurisdiction of the Courts of the country of incorporation of the Organiser for all purposes in relation to this Agreement and waives any objections on the ground of venue or forum non convenience or on similar grounds.

32. **Revocation** - Upon termination of this Agreement the license granted is revoked and thereupon the Exhibitor shall immediately leave the Alliance Expo premises and remove all its Exhibits.

33. **Exhibitor Rules & Regulation & Floor Plan** - The Organiser may at any time and from time to time make further rules and regulations (having immediate effect) in relation to any aspect of the Alliance Expo. Such rules and regulations shall be deemed to form part of this Agreement, and shall be binding on the Exhibitor. The Organiser may time to time be entitled to change the exhibit floor plan.

34. **Partial Invalidity** - The invalidity or unenforceability of any provision of this Agreement shall not affect the validity or enforceability of any other provision herein.

35. **Remedies and Implied Waivers** - No failure or delay on the part of the Organiser to exercise, any right or remedy under this Agreement will operate as a waiver thereof, nor will any single or partice exercise of any right or remedy preclude any other or further exercise thereof or the exercise of any other right or remedy. The rights and remedies provided are cumulative with and not exclusive of any rights or remedies provided by law independently of this Agreement.

36. **Set-Off Clause** - The Organiser and its Management may in its sole discretion, deduct from or setoff against any money due from the Organiser and its Management to the Exhibitor, any sum which the Exhibitor is liable to pay to the Organiser and its Management.

37. **Compliance Clause** - The Exhibitor shall, upon the Organiser's written request, forthwith take all necessary action and/or refrain from any further action which is, in the Organiser's view, necessary to comply with any of its obligations and, forthwith provide any necessary information or documents to evidence such compliance.

38. **Amendments Clause** - This Agreement shall be amended only in the form prescribed by the Organiser for such purposes from time to time.

39. **Assignment Clause** - The Organiser and its Management may without the consent or approval of the Exhibitor assign or transfer its rights and/or obligations under this Agreement. The Exhibitor may not assign or transfer any of its rights or obligations under this Agreement.

SIGNED at _____ on _____

AS WITNESS:

AS EXHIBITOR:

(Name of witness in print)

(Name of exhibitor in print)

SIGNED at _____ on _____

AS WITNESS:

RLM COMMUNICATIONS

Alliance Expo Organiser

(Name of witness in print)

(Name in print)



**ALLIANCE EXPO DURBAN
COMMERCIAL & PLATINUM EXPO BOOKING FORM**
Alliance Group (Pty) Limited: VAT Number 4150195321

Company Name: _____

Registration Number: _____

VAT Number: _____

Contact Person: _____

Exhibitor Representative: _____

Designation in Company: _____

Company Address: _____

Email Address: _____

Mobile Number: _____

Telephone Number: _____

Fax Number: _____

ALLIANCE EXPO EXPERIENCE

Number of Expo's Booked: _____

Dates of 2010 Expo's: _____

Date of Current Expo: _____

Current Expo Stand No: _____

Products/Services supplied at Expo: _____

Stand Category 1 Exhibitor
(circle correct option)

Stand Category 2 Exhibitor
(circle correct option)

Cost to Company (incl VAT):

Commercial/Platinum - **R 3 990.00**

Technical Notes:

Requirement:

150 words (brief description of your Company)
Your Company logo

Material format:

PDF

Colour:

CMYK

Resolution:

300 DPI



NO CHARGE FOR _____ ALLIANCE EXPO
(Please fill in this option)

Yes

Client Signature of Approval: _____

Date: _____

On signature of this Form, it is tacitly understood that the Rules & Regulations for the Exhibitors (attached), have read, understood and accepted by the Exhibitor. Please note that payment must be made immediately on signature of this Form. Confirmation of payment must be faxed to 021 443 6097.

Banking Details:

Bank Account Name:

Bank Name:

Account Number:

Branch Code:

Electronic Funds Transfer required

Alliance Group Kwazulu Natal (Pty) Ltd

Nedbank

1186044624

118 602

PLEASE USE REFERENCE:

Alliance Expo